

Universal-B

Conveyor system closure designed as an enclosed, versatile slider

Product description

A versatile solution with smooth surfaces for high aesthetic standards: The robust slider closure features an encapsulated design. When parked, the slider is positioned inside the casing. The system consists of a load-bearing steel structure lined with Promatect H panels. Walls can be completely replaced by storey-high elements. Universal-B is ideally suited for interrupted and separated conveyor systems, e.g. belt, roller and suspension chain conveyors, sorters and newspaper conveyors.

Type Fire protection closure as part of track-bound conveyor systems

Re-opening manual

Closing direction from left to right • from right to left • From top to bottom • from the bottom to the top

Conveyor system Interrupted conveyor system • Continuous belt conveyor system • Continuous travelling carriages • Sorter • Newspaper conveyor • Continuous suspension chain conveyor • Continuous roller conveyor system • Continuous conveyor system • Sloping track • Round belt conveyor

Fire resistance T 90

Constructive system design (Horizontal)

Required wall quality

Masonry	$d \geq 240 \text{ mm}$
Concrete	$d \geq 140 \text{ mm}$
Aerated concrete	$d \geq 200 \text{ mm}$

Technical feasibility

LH	200 mm - 2700 mm
LW	200 mm - 2500 mm

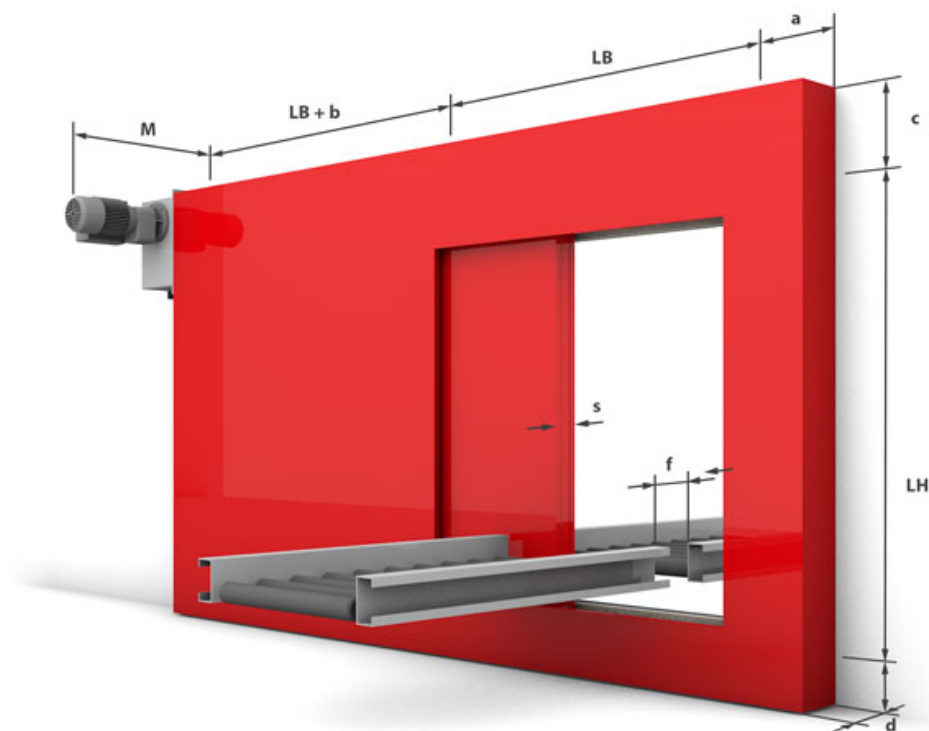

a = 220 (375) **b** = 258(310) **c** = 300(350) **d** = 145 **s** = 74 **M** = 485

Constructive system design (Vertical)

Required wall quality

Masonry	$d \geq 240 \text{ mm}$
Concrete	$d \geq 140 \text{ mm}$
Aerated concrete	$d \geq 200 \text{ mm}$

Technical feasibility

LH	200 mm - 2700 mm
LW	200 mm - 2500 mm

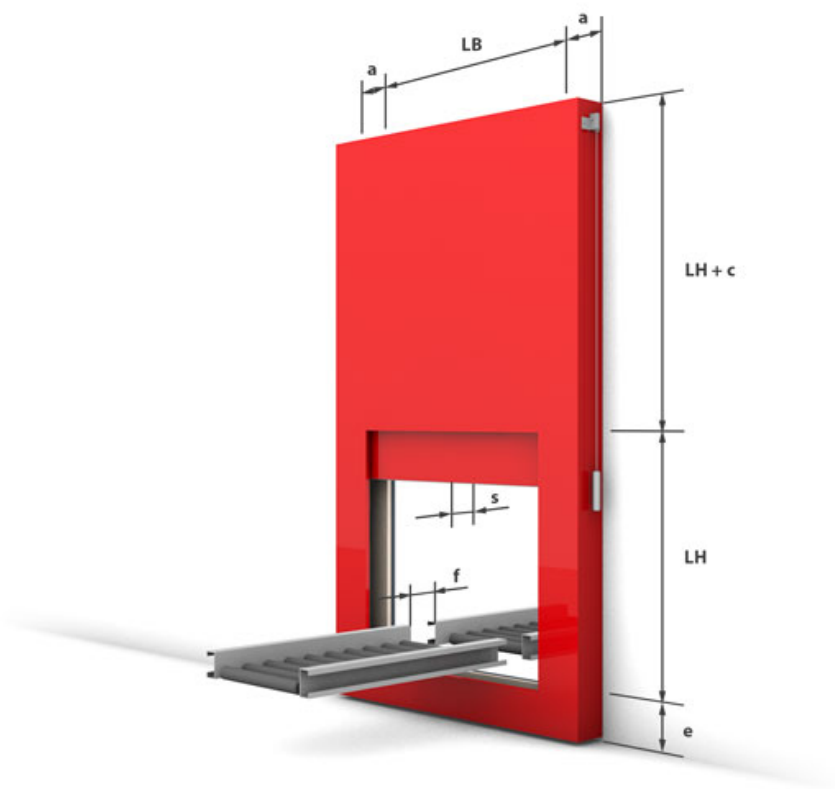

a = 200(230) **c** = 280(310) **e** = 165 **s** = 74